

THERMEAU®

RESIDENTIAL AND COMMERCIAL POOL HEAT PUMP



OWNER'S Manual

Table of contents

Introduction	3
General Safety Instructions	5
Thermeau Models' Specifications	6
Installation Instructions	
Location	7
Water piping	10
Multiple Heat Pump Connections	11
Electrical	12
Bonding	12
Bonding and plumbing step-by-step instructions	12
Electrical Connections	13
Electrical Diagrams	15
Service Analyzer Control	16
Electronic Temp. Controls	15
Initial Startup	19
Meaning of Display Codes	20
Troubleshooting	21
Requesting Assistance or Service	23
Maintenance	23
Winterizing	23
Pool Heat Pump Warranty	24

Thank you for buying a THERMEAU pool heat pump.

The THERMEAU pool heat pump is a self-contained unit designed specifically for pool heating. Each component has been selected with care to achieve a high-quality product in an effort to exceed all industry standards.

All THERMEAU pool heat pumps have a Scroll compressor, an electronic board with service analyzer, a titanium heat exchanger tube warranted for 10 years against corrosion. All components are of superior quality, which presents you with an effective, state-of-the-art technology heat pump.

In general, compared to other types of pool heaters, such as gas or oil-fired, the THERMEAU pool heat pump has a lower heating capacity on a BTU/hr basis. Therefore, it needs to operate for a longer time to accomplish the desired results. Occasionally, it may be necessary to run the heat pump for up to 24 hours per day. However, this should not be of concern to the owner because the heater is designed to operate continuously. What's more, despite continuous operation, it will still heat the pool far more economically than other types of heaters.

Please read carefully

Whenever you call to request service for your heater, you must know your complete model and serial numbers. You can find this information on the name plate located on the right side of your heater.

Please also record the purchase date of your device and your dealer's name, address, and telephone number.

Model Number _____

Serial Number _____

Purchase Date _____

Dealer Name _____

Dealer Address _____

Dealer Phone _____

Keep this book and the sales slip together in a safe place for future reference.

Service can now be obtained by calling these phone numbers.

CANADA: 1 855 661-9330

USA: 1 855 385-6480

General Safety Instructions

We care for our customers

We have provided important safety messages in this manual and on your heater. Always read and obey all safety messages.

IMPORTANT



The **IMPORTANT** sign calls attention to a note that provides important information or information essential to the completion of a task.

CAUTION



The **CAUTION** sign denotes a hazard. It calls attention to an operating procedure, practice, or the like, which, if not correctly performed or adhered to, could result in material damage, particularly to the product, up to the destruction of part or all of the product.

WARNING



The **WARNING** sign denotes a hazard. It calls attention to a procedure, practice, or the like, which, if not correctly performed or adhered to, could result in personal injury or injury to a third party. These signs are rare, but are extremely important.

IMPORTANT



This appliance is not intended for use by persons (including children) with reduced physical, sensory, or mental capabilities, or lack of experience and knowledge, unless they have been given supervision or instruction concerning use of the appliance by a person responsible for their safety. Children should be supervised to ensure that they do not play with the appliance.

CAUTION



All electrical connections must be done by a qualified electrician and according to the local electrical codes. Always cut off the unit's main power whenever the access panel is open or removed. Always install the machine outdoors (unless otherwise approved by the manufacturer), while respecting the minimal clearances needed for proper operation and heating.

CAUTION

Proper pool chemistry is vital to the life of your heater. Pay particular attention to the total alkalinity and TDS. It is highly recommended that you have your pool chemistry checked often by an independent pool store.

Water quality standards that must be strictly observed

Description	Normal Range	Verification
pH level	7.2 to 7.8	Once/week
Chlorine concentration	1.0 to 3.0 ppm	Once/2-3 days
Total alkalinity	80 to 100 ppm	Once/2-3 weeks
Total dissolved solids (TDS)	Below 1600 ppm (fresh water)	Once/month
Calcium hardness	200 to 300 ppm	Once/month

A robust and reliable product line Residential

SPECIFICATIONS	P65 / S65 / TH65	P85 / S85 / TH85	P105 / S105 / TH105	P125 / S125 / TH125	P140B / S140B / TH140B
Volts	230	230	230	230	230
Hertz	60	60	60	60	60
Phase	1	1	1	1	1
RLA (running load amps)	18,5A	24,7A	32,1A	32,1A	32,1A
LRA (locked rotor amps)	124A	166A	148A	185A	185A
Fan motor maximum load amps	2,4A	2,4A	2,4A	2,4A	2,4A
Fan motor (HP)	1/3	1/3	1/3	1/3	1/3
Fan motor speed (RPM)	825	825	825	825	825
Minimum circuit ampacity (MCA)	25,5A	33,3A	42,5A	42,5A	42,5A
Maximum overcurrent protection (MOP)	40A	50A	70A	70A	70A
Refrigerant	R-410A	R-410A	R-410A	R-410A	R-410A
Refrigerant charge (oz)	64	64	70	70	94
Minimum water flow (gallons per minute)	20	30	30	40	57
Optimal water flow (gallons per minute)	27	36	45	52	57
Maximum water flow (gallons per minute)	70	70	70	70	70
Maximum working water pressure (PSI)	75	75	75	75	75
Maximum water temperature	104 °F	104 °F	104 °F	104 °F	104 °F
Dimensions (in.)	L:39 W:33 H:34	L:39 W:33 H:34	L:39 W:33 H:34	L:39 W:33 H:34	L:39 W:33 H:34

A robust and reliable product line

Commercial

SPECIFICATIONS	C205-3A
Volts	575
Hertz	60
Phase	3
RLA (running load amps)	12,8A
LRA (locked rotor amps)	80A
Fan motor maximum load amps	1,1A
Fan motor (HP)	1/3
Fan motor speed (RPM)	1100
Minimum circuit ampacity (MCA)	17,1A
Maximum overcurrent protection (MOP)	30A
Refrigerant	R-410A
Refrigerant charge (oz)	144
Minimum water flow (gallons per minute)	60
Maximum water flow (gallons per minute)	90
Maximum working water pressure (PSI)	75
Maximum water temperature	104 °F
Dimensions (in.)	L:39 W:33 H:48

Installation Instructions

Location

The placement of the pool heater is very important in keeping installation costs to a minimum while providing for maximum efficiency of operation, as well as allowing adequate access for service and maintenance.

The THERMEAU pool heat pump is designed for outdoor installation and should not be installed in a fully enclosed area, such as a shed, garage, etc. Recirculation of cold discharged air back into the evaporator coil will greatly reduce unit heating capacity and efficiency.

The unit should be located as close as practical to the existing pool pump and filter to minimize water piping.

Mount the unit on a sturdy base, preferably a concrete slab or a set of blocks. The size of the base should not be less than 36" x 36" (91 cm x 91 cm).



IMPORTANT

All THERMEAU pool heat pump models feature ultrasilent ventilation systems. Air is pulled through the evaporator coil and discharged through the top grille. A minimum clearance of 48 inches should be allowed above the unit for unrestricted air discharge. The unit must not be installed under a porch. Any side of the unit should be located at least 12 inches from a wall or from any other obstruction for unrestricted air intake and service access. The back side of the unit or one of the two sides (left or right) could be installed at 6 inches from any obstruction as long as the two other sides are at a minimum of 12 inches distance of any obstruction. For commercial or multiple installation, please call us.

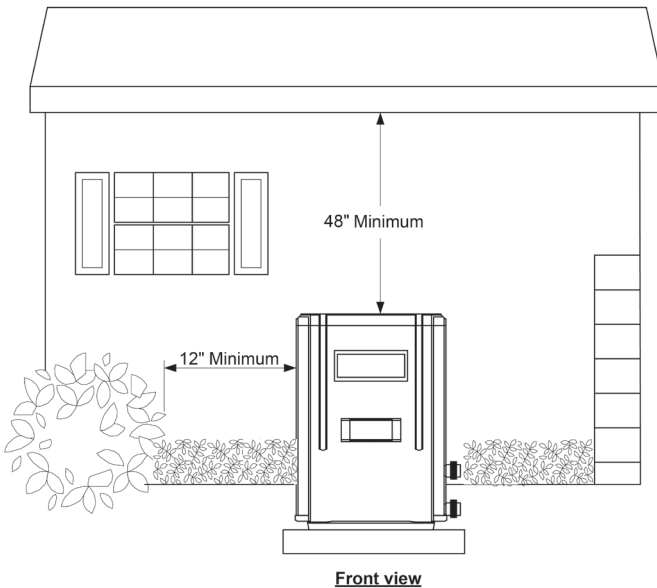
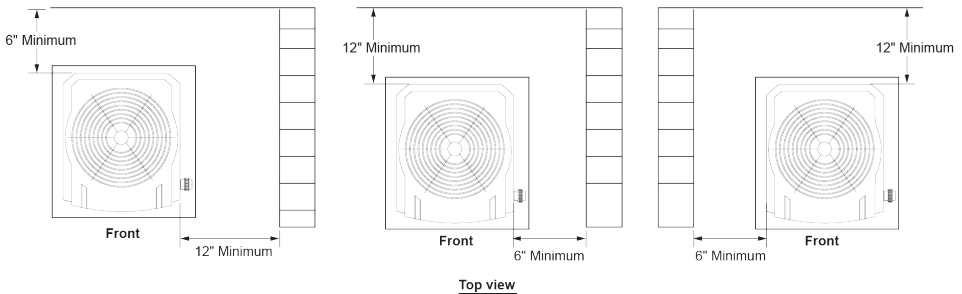

In compliance with the Florida Building Code 301.13, pool heat pumps must be anchored to a structure for hurricane resistance.

Anchor clamps are required on each installation.

Installation :

1. Place the **THERMEAU® Heat Pump** at its permanent location on the equipment pad.

Installer to provide 1/4" x 1-3/8" stainless steel anchor bolts and the suitable concrete anchor to attach the clamp to the equipment pad.

2. Place the clamps at the bottom of the **THERMEAU® Heat Pump** as indicated (**Fig. 1**).
3. Hook each clamp over the lip at the base between the lip of the panel and the evaporator coil guard as indicated (**fig. 2**).
4. Mark the position of the hole in each clamp on the backing material.
5. Drill a hole (1 - 1 1/2") at each mark into the equipment pad.
6. Insert a bolt anchor in each hole completely.
7. Line up anchor clamp holes and bolt anchors. Make sure that the hooks are over the lip of the **THERMEAU® Heat Pump** base (**fig. 2**).
8. Put an anchor bolt in each clamp anchor and secure the clamp and **THERMEAU® Heat Pump** to the equipment pad.

Figure 1. Anchor Clamp Positions

Attach anchor brackets to base of heat pump where indicated by the arrows.

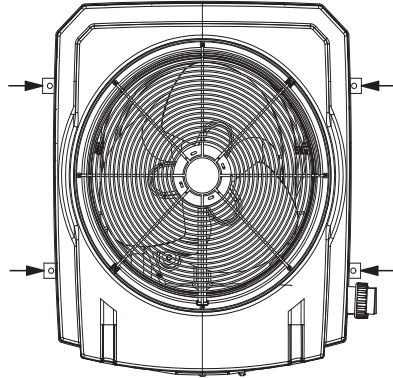
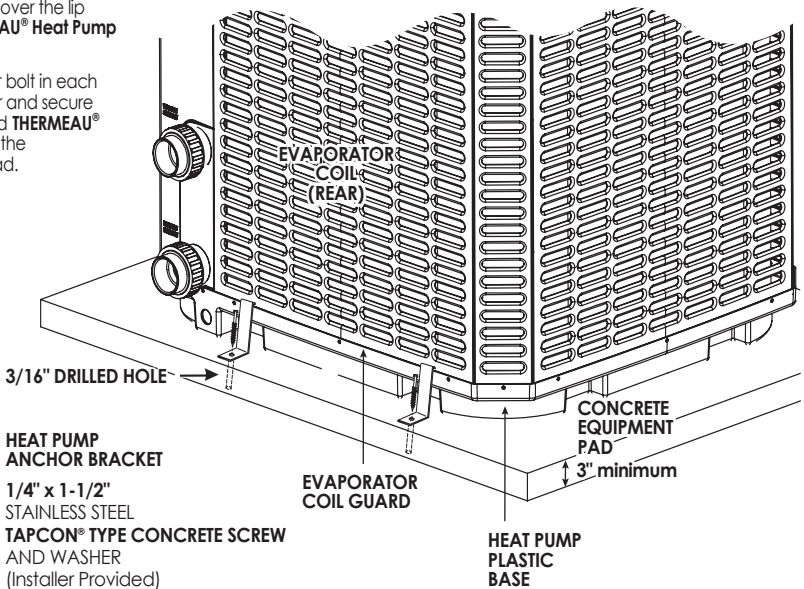

Figure 2. Anchor Clamp Installation



Water piping

? IMPORTANT

The piping sequence is as follows: pool pump > filter > heater > pool. Automated chlorine distribution systems, if used, must be placed downstream of the heater to minimize harm to the pool equipment. Use rigid PVC piping if possible (SCH40 or SCH80). All joints should be glued with PVC glue. If rigid PVC is not available, you can use soft or flexible piping with stainless steel clamps. When the piping installation is complete, operate the pool pump and check the system for leaks. Then, check the filter pressure gauge to verify that there isn't any indication of excessive pump head pressure.

You can also make the connections using high-pressure flexible hose, but make sure the hose can withstand high pressure. The installation of a bypass is not necessary unless the water flow exceeds the maximum gallons per minute (GPM).

Fig. 2

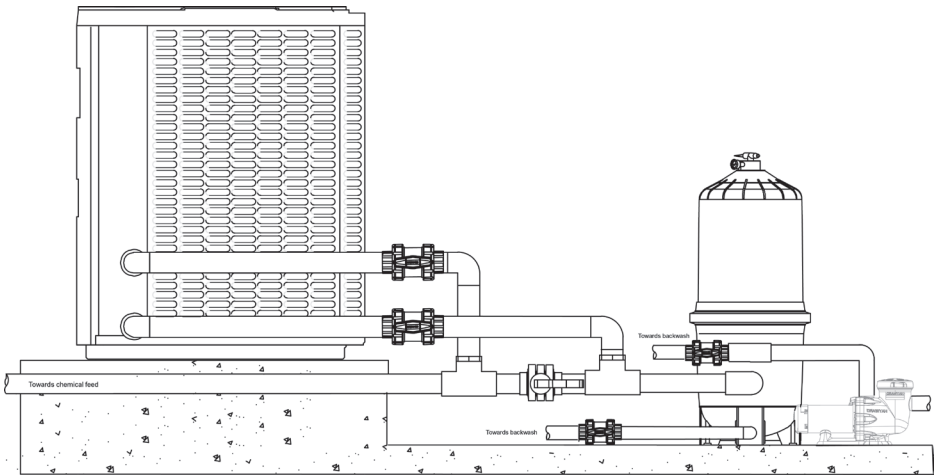

Multiple Heat Pump Connections

All plumbing on multiple heat pump installations must be done in parallel. An equal flow of water to each heat pump is important for optimum operation.

NOTE: It may be necessary to adjust water pressure switch if a unit is installed below the water level.

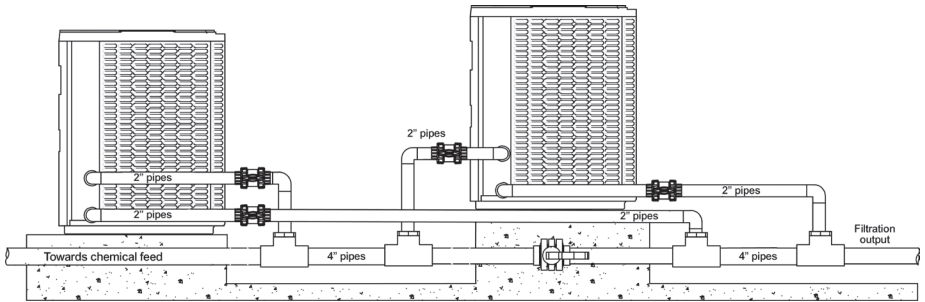

Fig. 3

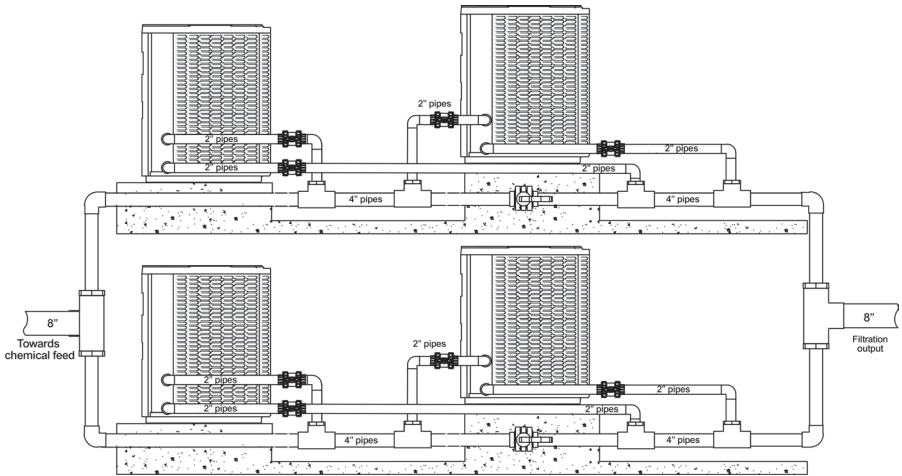

Fig. 4

Electrical

CAUTION

The wiring of your THERMEAU pool heat pump should be performed by a qualified electrician in accordance with local requirements. The appliance shall be installed in accordance with national wiring regulations.

WARNING

The unit must always be deactivated before opening the access panel. It is a requirement that a local disconnect is in place at the time of installation.

Bonding

WARNING

Because all metals have different electrical potentials, all metal and electrical components of the pool system must be bonded together. This includes the metal framework of the pool, the light, the pump, the filter (if made out of metal), the heater, any automatic chlorine generator, and any other metal or electrical equipment. On some older pools, this substructure bond wire may not exist. In these cases, a 6 to 8 foot solid copper rod must be driven into the ground near the equipment. All electric and metal components must then be bonded to each other, and then to the copper rod.

Bonding and Plumbing step-by-step instructions

1. A 1/3 lb check valve must be installed between the heater and any automatic chlorine distribution system (if used).
2. Any kind of automatic chlorine distribution system must be installed after or downstream of the heat pump.
3. The filter must be placed before or upstream from the heat pump.

Electrical Connections

WARNING

The installation of the THERMEAU pool heater should be performed by a certified electrician. To connect the electricity, follow these steps:

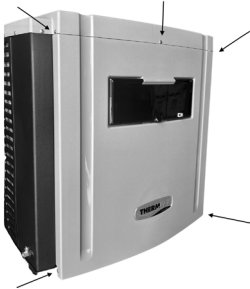

Step 1: Unscrew the five front panel screws.

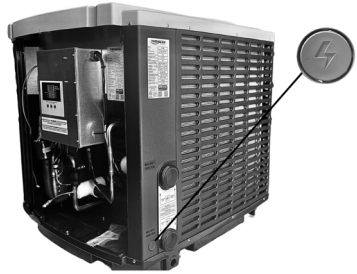

Step 2: Insert the power cord into one of the holes on the right or left side of the unit.



Step 3: Install the 3/4" connector in the left corner of the electrical box.



Step 4: Insert the power cord through the connector into the electrical box.



Bonding

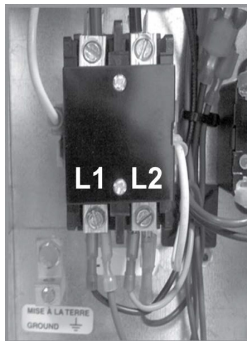

Step 5: Connect the wires in the electrical box to L1, L2 and the ground terminal.

Electrical Connections

WARNING

Instructions for the electrical connection of the C205-3A models:

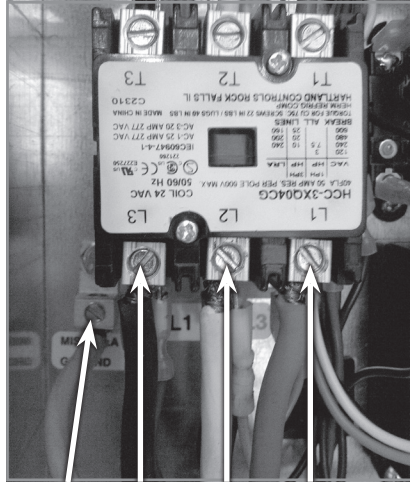

Ground L3 L2 L1

3 Phase loss and reversal protection

Operating mode:

The THERMEAU unit is equipped with SCROLL compressor which cannot run in both rotations. When the heating light on the main board will come on, If all three phase are relatively equal and in proper sequence, the (ON) green light on the phase protector will be energize and the compressor will start normally. If the phase are in wrong sequence, that'll be the (FAULT) red light that come ON and the compressor won't start. If this occurred, you have to switch the L1 wire with L2 wire.

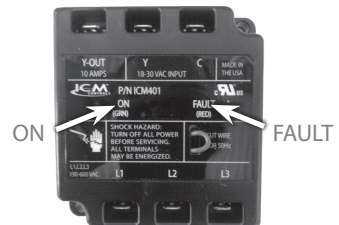

Wiring Diagram

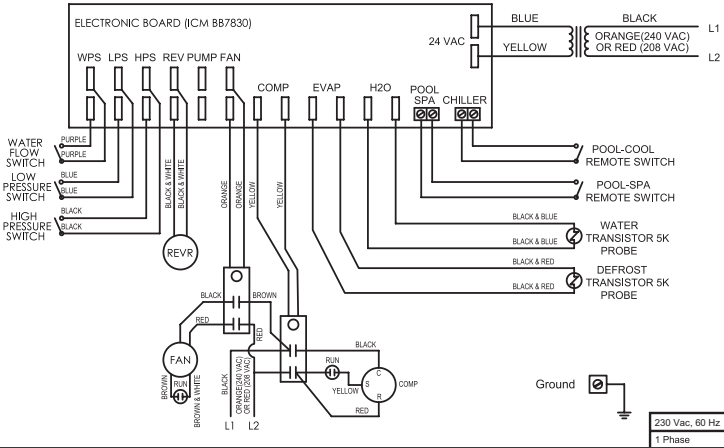

Wiring Diagram

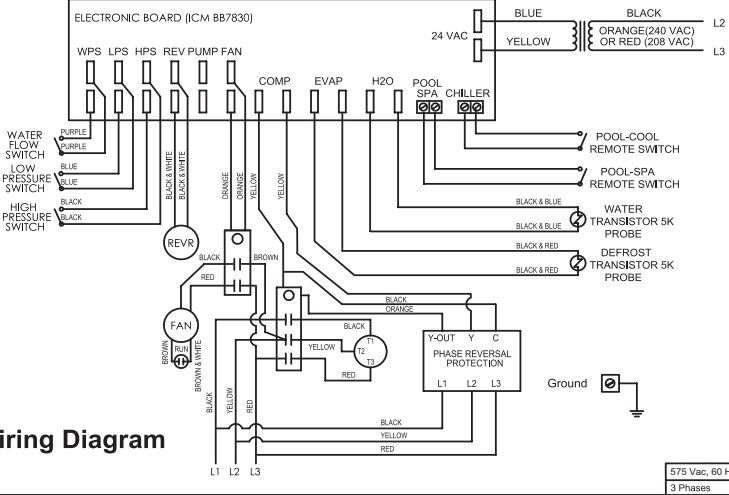

Service Analyzer Control

The control panel is factory set to display the temperature in Fahrenheit degrees.

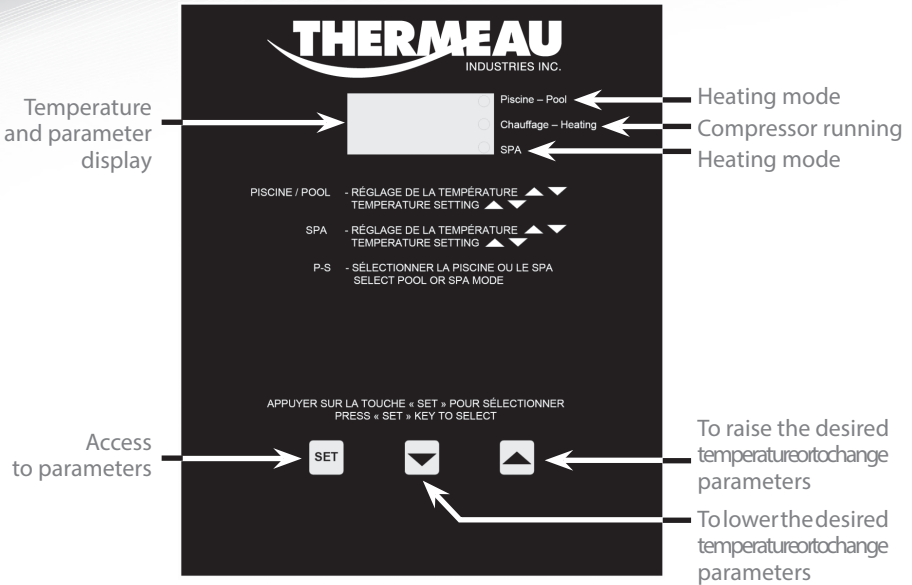

Fig. 5

Electronic Temp. Controls

All units

Description

The control located on the front of your heat pump has a large three-character display for the water temperature, set points, and diagnostics (see figure 5 for front panel appearance). The three button keypad includes SET, DOWN arrow, and UP arrow buttons. LED indicators next to the display show if the heat pump is in the pool mode or in the spa mode and if the unit is running.

Buttons:

Press the SET button to change between modes and use the UP and DOWN arrows to change the selected mode's settings.

Modes available are:

ON OFF Allow you to switch the unit ON or OFF .

POOL Allows you to change the pool water temperature set point.

SPA Allows you to change the spa water temperature set point.

P-S Changes between pool and spa settings. LED's on front panel will indicate current mode selected.

Water Temperature Set Point

Temperature set point range is 51°F to 95°F for POL mode. For SPA mode, set point range is 51°F to 104°F. Pushing the UP arrow or DOWN arrow buttons will prompt the control to display the current set point. Continuing to press the UP or DOWN arrows will allow the set point values to scroll until the desired set point is reached. Once the new set point has been reached, stop pressing the UP or DOWN arrows. Once the unit toggles back to the current water temperature display, the set point is entered. The controls have a feature called "Set Point Memory Retention". If the power is removed from the unit, it retains the last set point displayed.

Heat/Cool Operation (Prestige Series Only)

The heat/cool model is designed to both heat and cool the pool. To select heat or cool mode, push the set key until H/C is displayed. Press the DOWN arrow key to select heating (HEA), or the UP arrow key to select cooling (COL). Set the desired setpoint temperature as described on page 16.

When the heating mode is activated and the unit is running, the letters HEA will be flashing in alternately with the pool temperature.

When the cool mode is activated and the unit is running, the letters COL will be flashing in alternately with the pool temperature.

When the automatic mode is activated and the unit is running, the letters AUT will be flashing in alternately with the pool temperature.

When the automatic mode is activated, the unit will HEAT the pool when the temperature drop 0,5°F below set point and will automatically switch to COOL mode when the temperature raise 2,5°F over set point.

Unit will not cool:

FOR h/c UNITS: Make sure P-S is set to "POL" mode as unit will not cool in "SPA" mode.

Connecting to a Remote System

This Pool Heater is compatible with most of all known remote systems in the industry. The following models' diagrams show how to connect all of the remote systems to the Electronic Temp. Controller.

For 2 wire remotes

1. Bring up "POL" setting and arrow temperature down until pool setting reads "OFF".
2. Bring up "SPA" setting and arrow temperature up until spa setting reads 104.
3. Set unit to the "POL" mode.
4. Connect remote system with 2 wires to the POOL/SPA terminal on control board. Figure 6 shows you where to connect the 2 wire remote systems to the temperature controller.

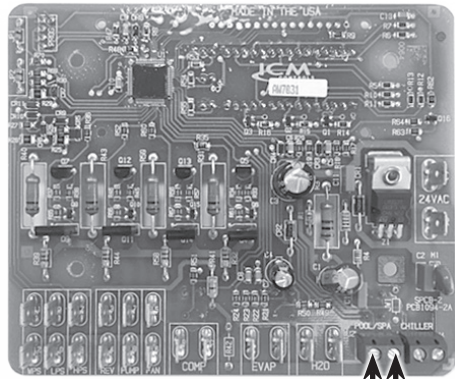

Fig. 6

For 3 wire remotes

1. Bring up "POL" setting and use arrows to select desired pool temperature.
2. Bring up "SPA" setting and use the arrows to select the desired spa temperature.
3. Set unit to "POL" mode.
4. Connect the commun and high (or spa) wires to the "POOL/SPA" terminals on control board (see specific model diagram). Low or pool wire does not get connected.

Initial Startup

? IMPORTANT

Before starting the pool heater for the first time, it is important to verify that the breaker is in the ON position.

Also make sure that the water circulates freely and that the pool pump is activated.

Then, you will need to set the water temperature you desire. The fan will immediately start. The compressor will start after a 3 to 4-minute delay.

When the compressor is running, the HEATING/CHAUFFAGE indicator located on the right (see "Service Analyzer Control," p.15) should be lit. At initial startup, it is normal for the unit to run 24 hours a day.

It is also normal to see water dripping from the holes at the base of the unit. This is simple condensation.

Meaning of Display Codes

Service Analyzer Codes

Most problems will be detected by the service analyzer and a code will be displayed on the digital display of your heater.

Display Meaning of codes

OFF	The desired programmed temperature point is lower than 60°F (15°C).
LP & LP3	Shortage of refrigerant gas in the unit or faulty low pressure control. The digital display will show LP3 after 3 LP faults and shut down your pool heater. The pool pump will also be stopped for protection if the unit's internal time clock feature is used. If LP or LP3 occurs you should call for service.
HP & HP3	Low water flow TO the unit or faulty high pressure control. Check water flow. Backwash filter and/or heater. The unit will show HP3 after 3 HP faults. This will stop your heater for protection.
PO/DPO	Water temperature probe is short circuited or may be defective.
FLo & FL3	Possible causes: <ul style="list-style-type: none">- The FIL parameter must always be set to OFF.- The filter is in backwash position.- The filter pump is stopped.- The filter is dirty.- Shortage of water to pool pump.- Water pressure switch must be adjusted or it is broken.- The unit is in the protection mode and will show FL3, press any key to restart the unit. FL3 code will stop your heater for protection.
PC/DPC	Suction temperature probe is short circuited or may be defective.
FS	Unit currently in defrosting cycle (the fan works but the compressor is stopped). This is normal operation when outside temperatures are cold.

Troubleshooting

The pool heater is not running.

-
- | | | |
|---------------------------------------|-----|--|
| Heat pump control set to OFF. | ••◆ | Raise temperature set point above 60°F (15°C). |
| Desired water temperature is reached. | ••◆ | Unit will automatically restart when the water temperature goes below the set point. |
| Main breaker is tripped. | ••◆ | Reset it. |
-

The heater is displaying “flo” and it will not start.

-
- | | | |
|--|-----|----------------------------|
| Pool pump is not running. | ••◆ | Turn the pool pump on. |
| Filter is dirty, restricting the water flow. | ••◆ | Backwash and clean filter. |
-

The fan is running, but the compressor is not.

-
- | | | |
|--------------------------------------|-----|--|
| The heat pump is in protection mode. | ••◆ | In this case, there may be a 5-minute delay before restarting. |
| The unit is on defrost cycle. | ••◆ | Digital display should indicate FS. The compressor will automatically start again a few minutes after the display stops indicating FS. |
-

There is no display and the fan is not running, but the compressor is running.

- ◆ Ask your electrician to verify your heat pump's power supply by checking over the L1 and L2 or L1, L2 and L3 connections in the unit's service box.

There is water around the unit.

While your THERMEAU pool heater is in the heating mode, a large quantity of warm and humid air passes over the evaporator and causes condensation. It is normal to see condensation dripping under the heater.

- ◆ To check if the water really is a leak, you must stop the heater and leave the pool pump running for over 5 hours. If water is still coming out of your heater after this period, then call your dealer for service.

The heater is running but desired water temperature cannot be reached.

- ◆ Heat loss is too much for the heater; cover your pool as often as you can.

Evaporator is dirty.

- ◆ Clean it.

- ◆ Evaporator restricted due to improper location (see section on locating the unit).

Restricted water flow.

- ◆ Adjust water flow.

Note: If your pool heater does not operate for reasons other than those mentioned above, please contact Consumer Assistance Center (see p.4) to obtain the proper authorization for the warranty to apply.

Requesting Assistance or Service



IMPORTANT

All service will be handled by an Authorized Service Center. Warranty may be voided if service is not done by an Authorized Service Representative. Do not return the heater to your dealer as they do not provide service.

Before calling for assistance or service, please check the “Troubleshooting” (p.20-21) and “Warranty” (p.23-24-25) sections or call your dealer. It may save you the cost of a service call. If you still need help, follow the instructions below.

Service can be obtained by calling one of these phone numbers.

CANADA: 1 855 661-9330

USA: 1 855 385-6480

When asking for help, please provide a detailed description of the problem, your heater’s complete model and serial number, and the purchase date (see p.4). This information will help us respond properly to your request.

Keep a copy of the sales receipt showing the date of purchase.

Proof of purchase will assure you warranty service.

Maintenance

Proper maintenance of your heat pump is essential to maintain its optimum level of performance and efficiency. Environmental characteristics such as ambient temperature, humidity, water temperature and wind speed play a crucial role in the efficiency of your heat pump. Therefore, it’s imperative that your heat pump installation takes these parameters into consideration to ensure optimum performance. Here are the key points to remember when it comes to maintaining your heat pump:

- Air coil maintenance : The air coil is an essential component of your heat pump, as it facilitates heat exchange with the outside air. It's vital to keep it clean and free of dirt and debris, which can impair the efficiency of the entire system. We recommend cleaning the air coil at least once a year, using a low-pressure water jet from a garden hose.

Please note that you do not need to remove the heat pump panels for maintenance.

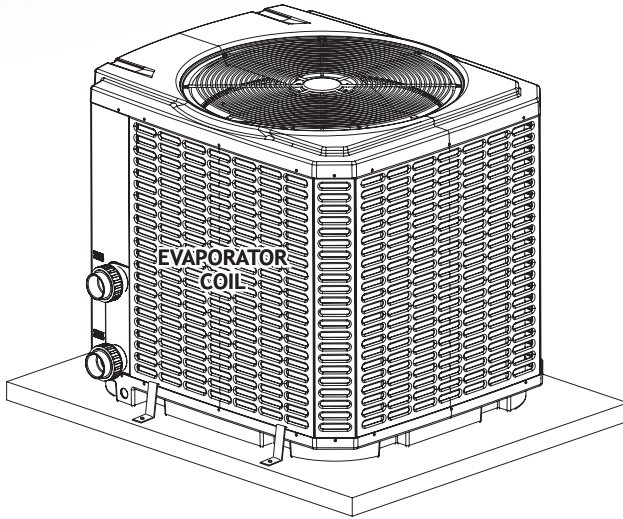

- Cleaning precautions : When cleaning the air coil, be careful not to bend the coil fins. These fins are designed to promote air circulation, and any deformation could impede this flow, resulting in reduced heat pump performance. It's vital not to use high-pressure cleaners on your heat pump equipment.

By following these tips and paying regular attention to the maintenance of your heat pump, you'll be able to extend its service life, maintain optimum performance and save on operating costs over the long term.

Winterizing

First, you must turn the breaker off. The unit must be drained of all its water. You will need to disconnect the IN and OUT water connections.

The next step is to reconnect your IN and OUT water connections that will have previously been drained.

It is recommended to cover the heat pump to prevent snow from getting inside.

Pool Heat Pump Warranty

Commercial use

Thermeau Industries inc. warrants that the pool heat pump will be free of defects in workmanship and materials. The heat pump will be warranted for a period of one (1) year. All parts and labor to correct any defect in workmanship or materials will be the responsibility of Thermeau Industries inc.

The compressor component of the Thermeau Industries inc. pool heat pump has a five (5) years limited warranty. During the first (1) year, the costs incurred by the parts and labor needed to repair the compressor will be the responsibility of Thermeau Industries inc. During years two (2), three (3), four (4) and five (5), only parts will be covered by the warranty.

The titanium tube portion of the heat exchanger in the Thermeau Industries inc. pool heat pump has a limited 10-year warranty. The titanium tube portion of the heat exchanger is warranted to the original owner and at the original address. All parts and labor are warranted for a period of one (1) year to the original home owner. After one (1) year, only the titanium tube portion of the heat exchanger part is warranted.

All Thermeau Industries inc. pool heat pump must be installed according to manufacturer's specifications or the warranty will be null and void.

All warranty work must be performed by a Thermeau Industries inc. authorized service center. All warranty work must be approved prior to service center performing the work.

Any alteration or repair by any person, agency or company not authorized by Thermeau Industries inc. will void the warranty. Thermeau Industries inc. is not liable for any damages of any sort whatsoever, including incidental and consequential damages. This warranty does not include damage to any internal piping or components due to freezing conditions, negligence, abuse, routine maintenance inspections, electrical wiring outside the heat unit, service calls caused by owner, external valve position, refrigerant or other expendable materials, installations in corrosive environments or atmospheres, nor acts of God. There are no particular warranties of merchantability that apply to this product.

This warranty applies to Canada and the United States.

Thermeau Industries inc. will replace or repair any parts that are defective providing such parts are returned to the Thermeau Industries inc. factory, freight collect, within the warranty period. The above is the exclusive remedy from Thermeau Industries inc.

No need to register your product, simply keep your receipt of purchase to apply warranty.

Pool Heat Pump Warranty

Residential

Thermeau inc. warrants that the heat pump pool heater will be free of defects in workmanship and materials. The Prestige and Premium heat pumps will be warranted for a period of five (5) years on labor and parts. The Signature heat pump will be warranted for a period of three (3) years on labor and five (5) years on parts. During this period, all parts and labor to correct any defect in workmanship or materials will be the responsibility of Thermeau inc.

The titanium tube portion of the heat exchanger in the heat pump pool heater has a limited 10-year warranty. The titanium tube portion of the heat exchanger is warranted to the original owner and at the original installation address. All parts and labor for the Prestige and Premium heat pumps are warranted for a period of five (5) years to the original home owner. All parts for the Signature heat pump are warranted for a period of five (5) years and three (3) years on labor to the original home owner. After five (5) years, only the titanium tube portion of the heat exchanger part is warranted.

The manufacturer reserves the right to replace defective parts with new or refurbished parts at its sole discretion. All warranty work must be performed by a Thermeau inc. authorized service center. All warranty work must be approved prior to service center performing the work. This warranty is applicable only if the heat pump has been installed, operated and maintained expressly and completely in accordance with the owner's manual and the manufacturer's specifications. Any alteration or repair by any person, agency or company not authorized by Thermeau inc. will void the warranty. Thermeau inc. is not liable for any damages of any sort whatsoever, including incidental and consequential damages. This warranty does not include damage to any internal piping or components due to freezing conditions, negligence, abuse, routine maintenance inspections, electrical wiring outside the heat unit, service calls caused by owner, external valve position, refrigerant or other expendable materials, installations in corrosive environments or atmospheres, nor Acts of God. There are no particular warranties of merchantability that applies to this product.

This warranty applies to the USA and Canada only.

Thermeau inc. will replace or repair any parts that are defective providing such parts are returned to the Thermeau factory, freight collect, within the warranty period. The above is the exclusive remedy from Thermeau inc.

No need to register your product, simply keep your receipt of purchase to apply warranty.

Warranty for the State of Florida

Thermeau inc. warrants that the heat pump pool heater will be free of defects in workmanship and materials.

Prestige heat pump

The Prestige heat pump will be warranted for a period of five (5) years. During this period, all parts and labor to correct any defect in workmanship or materials will be the responsibility of Thermeau inc. After five (5) years, only the titanium tube portion of the heat exchanger part is warranted.

Signature heat pump

The Signature heat pump will be warranted for a period of two (2) years. During this period, all parts and labor to correct any defect in workmanship or materials will be the responsibility of Thermeau inc. All parts of Signature heat pump pool heaters have a seven (7) years warranty. After seven (7) years, only the titanium tube portion of the heat exchanger part is warranted.

The titanium tube portion of the heat exchanger in both heat pump pool heaters has a limited 10-year warranty. The titanium tube portion of the heat exchanger is warranted to the original owner and at the original installation address.

The manufacturer reserves the right to replace defective parts with new or refurbished parts at its sole discretion. All warranty work must be performed by a Thermeau inc. authorized service center. All warranty work must be approved prior to service center performing the work. This warranty is applicable only if the heat pump has been installed, operated and maintained expressly and completely in accordance with the owner's manual and the manufacturer's specifications. Any alteration or repair by any person, agency or company not authorized by Thermeau inc. will void the warranty. Thermeau inc. is not liable for any damages of any sort whatsoever, including incidental and consequential damages. This warranty does not include damage to any internal piping or components due to freezing conditions, negligence, abuse, routine maintenance inspections, electrical wiring outside the heat unit, service calls caused by owner, external valve position, refrigerant or other expendable materials, installations in corrosive environments or atmospheres, nor Acts of God. There are no particular warranties of merchantability that applies to this product. This warranty is valid for residential use only.

This warranty applies for the State of Florida only.

Thermeau inc. will replace or repair any parts that are defective providing such parts are returned to the Thermeau factory, freight collect, within the warranty period. The above is the exclusive remedy from Thermeau inc. No need to register your product, simply keep your receipt of purchase to apply warranty.



RESIDENTIAL AND COMMERCIAL POOL HEAT PUMP